

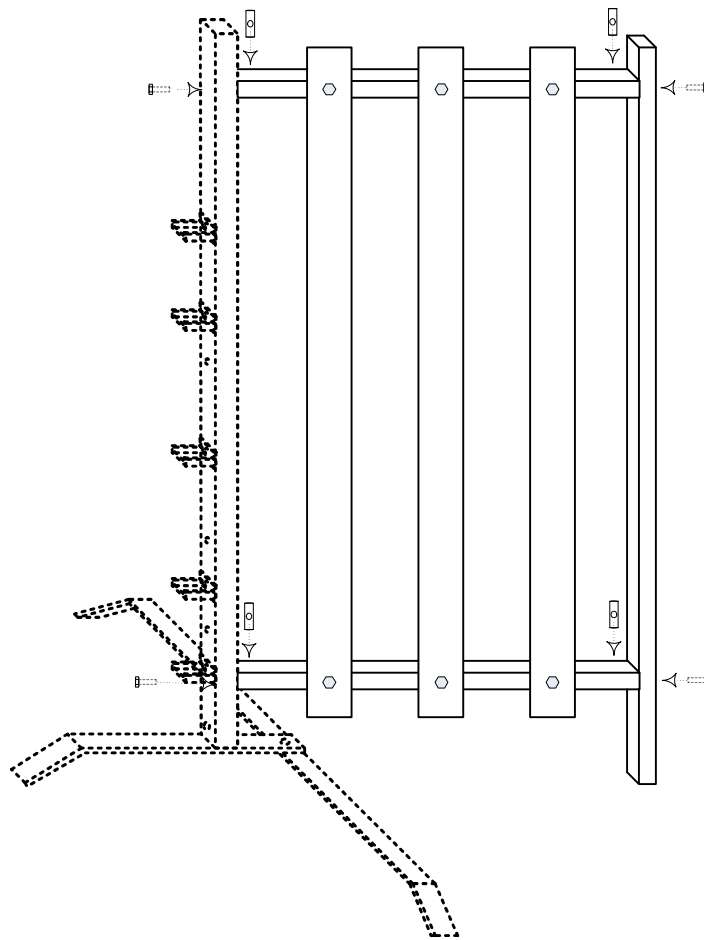

ALUMINUM WING JUMP ATTACHMENT ASSEMBLY INSTRUCTIONS





ALUMINUM WING JUMP ATTACHMENT PARTS LIST

- 1 Check the contained parts with the list
- 2 If parts are missing, logon to:
www.championagility.com and replacement parts
will be shipped out to you.

Part	Description	Qty
WJ-0001	Wing Main Support	2
WJ-0002	Wing Cross Support	4
WJ-0003	Wing Slats	6
HB-1500-2520	1.5" Hex Bolt	20
CD-1250-2520	1-1/4" Cross Dowel	8
HN-2520	1/4" Hex Nut	12
BW-1250	1/4" Lock Washers	20
SC-0002	3/4" Safety Cap	4

CHAMPION AGILITY

3 Attach a Wing Main Support to two Wing Cross Supports using two 1.5" Hex Bolts, two Cross Dowels and two Lock Nuts.

4 Attach the assembly from 3 to a Jump using two 1.5" Hex Bolts, two Cross Dowels and two Lock Nuts.

5 Attach three Wing Slats to the assembly from 4 using six 1.5" Hex Bolts, six Hex Nuts and six Lock Washers.

6 Press on two 3/4" Safety Caps onto the top and bottom of the Wing Main Support.

7 Repeat steps 3 through 6 for the other jump standard.

8 Paint the Wing Slats.

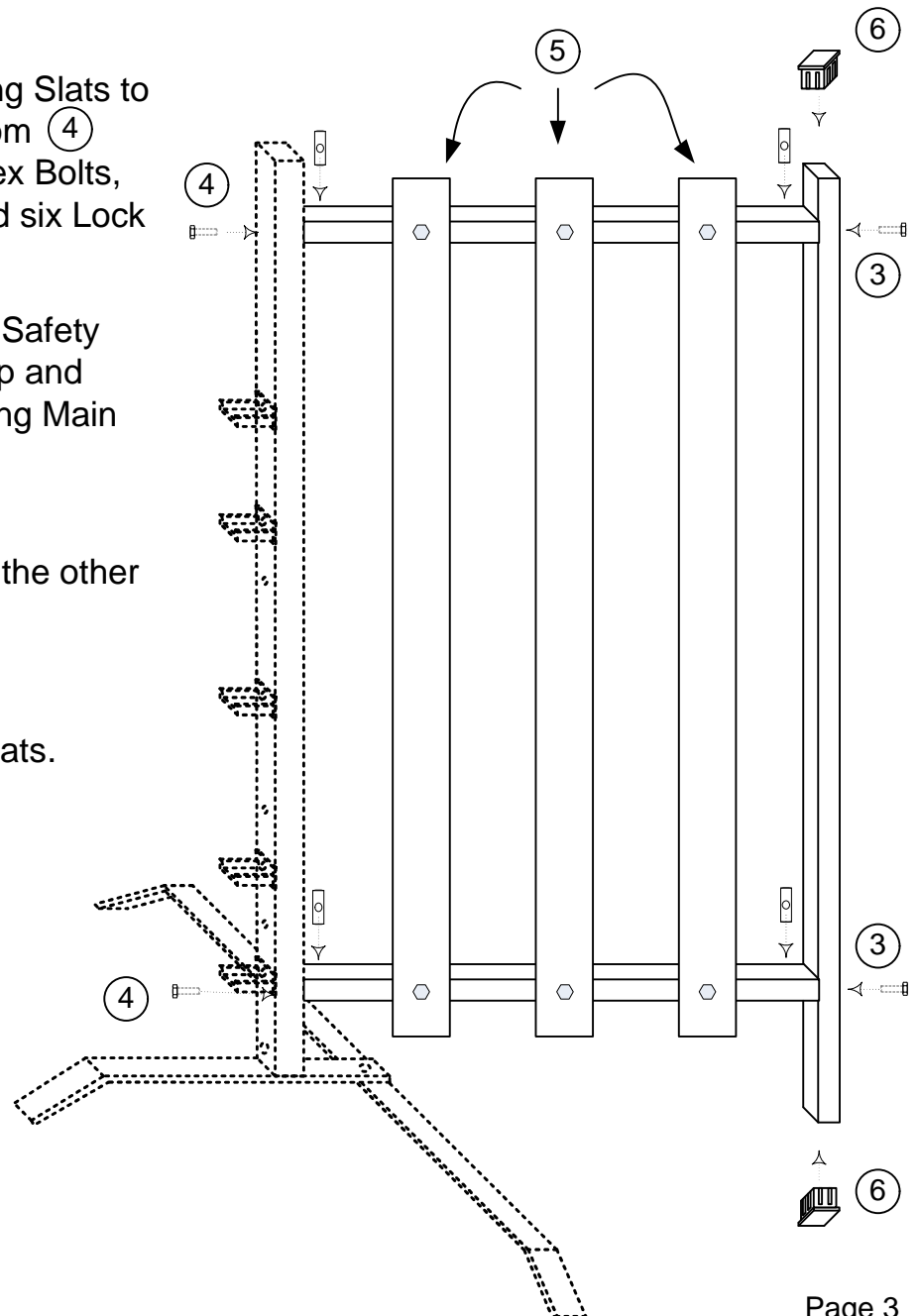



Warranty

1. For one year from the date of the original retail purchase. CHAMPION AGILITY warrants to the original purchaser of any CHAMPION AGILITY product that, should it prove defective by reason of improper workmanship and/or material, CHAMPION AGILITY will repair or replace, at its option, any defective part of the product, without charge for the part or the shipping. Replacement parts are warranted for the remainder of the original warranty period.

NOTE: If you discover that any pieces to your CHAMPION AGILITY product are missing when you unpack it, please visit www.championagility.com and the missing piece(s) will be sent to you at no charge.

2. THIS WARRANTY DOES NOT COVER defects in the equipment caused by the original purchaser or any third party, or any defects arising or discovered more than one year from the original retail purchase date.

3. STEPS TO OBTAIN WARRANTY SERVICE:

A. The purchaser must e-mail CHAMPION AGILITY at sales@championagility.com, to report the alleged defect to a customer service representative.

B. The customer service representative will determine if the defect is covered by this warranty and if it is, will authorize and instruct the purchaser in how to obtain corrective action.

C. CHAMPION AGILITY may require the purchaser to present the sales receipt or other proof of purchase prior to authorizing any return or replacement. No returns or replacements will be permitted without proper authorization. If a return or replacement is authorized, you may be requested to return the item to CHAMPION AGILITY or to make the item available for pick-up by CHAMPION AGILITY.

4. ANY EXPRESS WARRANTY NOT PROVIDED IN THIS WARRANTY DOCUMENT AND ANY REMEDY FOR BREACH OF CONTRACT THAT, BUT FOR THIS PROVISION, MIGHT ARISE BY IMPLICATION OR OPERATION OF LAW, IS HEREBY EXCLUDED AND DISCLAIMED. THE IMPLIED WARRANTIES OF MERCHANTABILITY AND OF FITNESS FOR ANY PARTICULAR PURPOSE ARE EXPRESSLY LIMITED TO TERM OF ONE YEAR.

5. UNDER NO CIRCUMSTANCES SHALL CHAMPION AGILITY BE LIABLE TO PURCHASER OR ANY OTHER PERSON OR ANY SPECIAL, INCIDENTAL OR CONSEQUENTIAL DAMAGES, WHETHER ARISING OUT OF BREACH OF WARRANTY, BREACH OF CONTRACT OR OTHERWISE.